

MILLING PLANT COMBI JUNIOR



With Stone Grinding Mill



80Kg/h

*Production 50/80
Kg/h (fine/coarse)*



*Strong and
resistant structure*



*High endurance
Stones*



For more than 70 years Partisani's Technology has been involved in innovation and research. Partisani is the leading company in the production of Stone Mills, granting to Mills and Pasta Factories a very high quality and organoleptic completeness product.



STONE GRINDING MILL MOD. MB 250

Since the ancient times, men utilize stones to grind cereals. In the course of the years new technologies have improved the Mill's frames in order to increase their efficiency and the grinded product quality looking for simple and cheap maintenance, but the grinding stone has remained the same. Today modern nutrition science has rediscovered the high value of Wholemeal Flours produced with Stone Grinding Mills, as they preserve all the vitamins and salts, so as they are inside the grain. Rural millers, bakeries, milling industries and agriculture utilize our Stone Mills, especially for Wholemeal Flour products. These Mills are built only for grinding dry products and not oily ones. Modern Stones are strong and wear resistant, they do not need dressing treatment and, above all, they produce soft and light flours.



The Stones are made only of natural materials such as emery and flint and a type of magnesite is used as binding. They are solid and have an excellent resistance which means a long duration. Stone Mill MB250 is built on strong welded stainless steel frame, resulting in elevated robustness. The hopper has a load capacity of about 20 kg and granules fall inside through an adjustable system. The fineness degree of the flour can be adjusted using a wheel that regulates the distance between the stones (nearer or larger). The upper stone is fixed, while the lower one is rolling and rotates by means of trapezoidal transmission belts, driven by a 1,8 KW electric motor which can be supplied single phase 230 Volts or three phase 400 Volts. The rolling stone is equipped with two small brushes to make easier the cleaning and the emptying of the grinding chamber.

CEREALS:

Wheat, Barley, Millet, Rice, Oat, Corn, Spelt, Kamut, Buckwheat, etc.

LEGUMES:

Broad beans, Lentils, Chick pea, etc.

SPICES: Pepper, Paprika, Salt, Coffee, etc.

Mod.	Net weight Kg	Gross weight Kg	Volume mc.	Power KW	Production fine/coarse Kg/h
MB 250	70	90	0.215	1.8	50 / 80

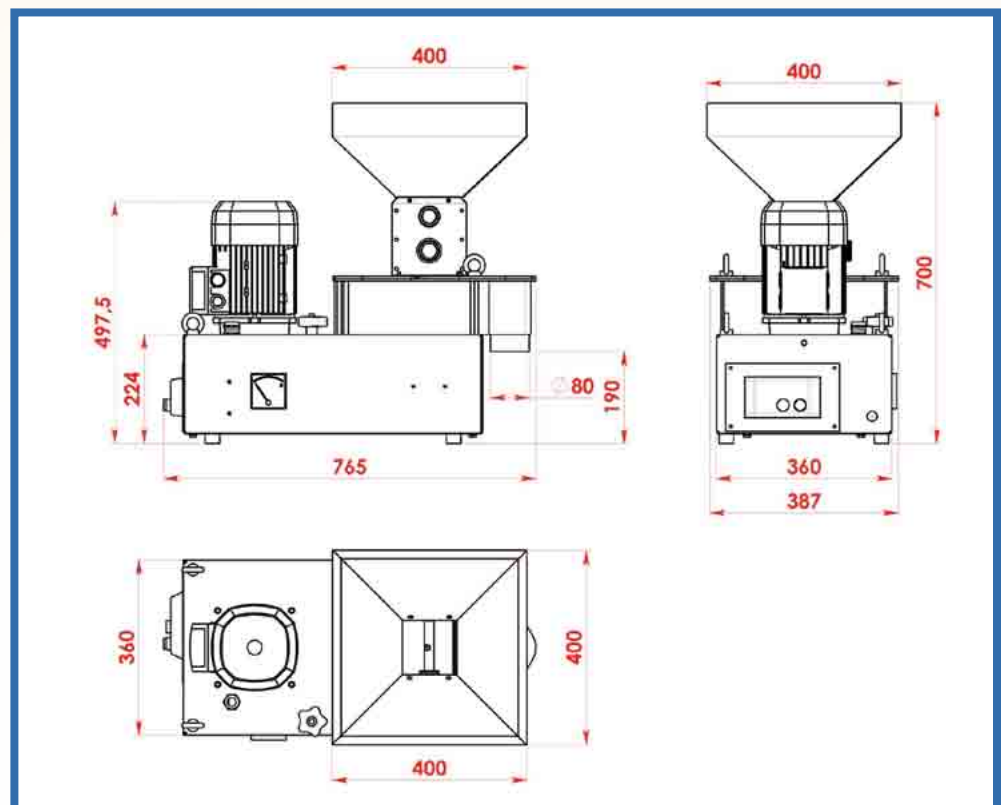

CENTRIFUGAL SIFTER MOD. BD 150



Our centrifugal Sifter may be considered the ideal completion for our Stone Mills, in case you need to sieve the wholemeal flour. It makes possible obtaining a high output with high percentage of extraction. A minimum driving power absorption is required. Our Sifter has very small overall dimensions, suitable to place on it our Stone Mill MB-250 and it works efficiently and simply. This machine combines the great flexibility of the flow diagram with the very simple and quick interchangeability of sieves. It allows to obtain three different selections: two types of flour and bran. The whole structure is in welded and furnace painted steel. A rotor, operating by centrifugal pulsation, is set up on ball dust-proof bearings. There are not brushes in contact with the sieves that can cause mesh wear and so meshes have long duration and high reliability. The Sifter is equipped with three separate discharge outlets to sack the different flours. Every discharge spout is filled with nozzles and leather lacers. The Sifter is driven by a single-phase 230 Volts - 0,12 KW electric motor, directly coupled with the shaft. The machine is equipped with safety switches on each small door which block the functioning in case of opening.

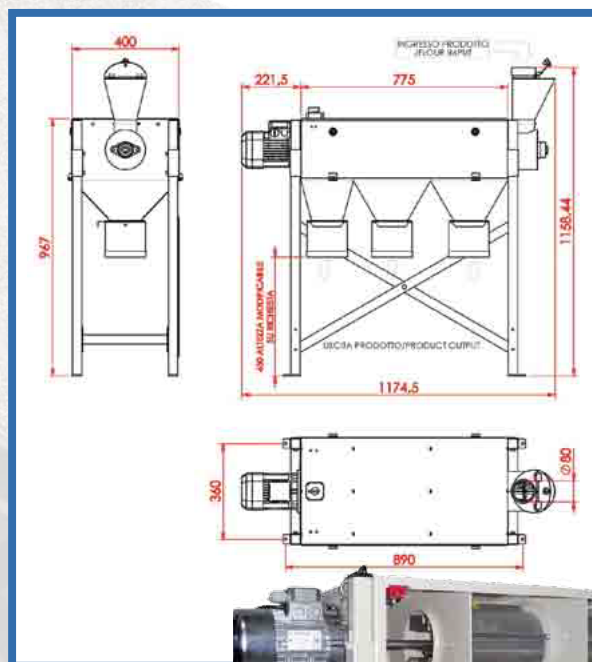

Mod.	Sieves lenght mm.	Sieves Ø mm.	Net weight Kg	Gross weight Kg	Power KW	Max production Kg/h
BD 150	2 X 238	150	60	90	0.18	75-80



PNEUMATIC SYSTEM MOD. SD 250

The new Pneumatic System SD-250 is the ultimate solution for who has the need to mill without stopping the production for several hours in a day. The application of this system allows the improvement of Combi Junior performances, making it a real professional Stone Milling Plant, small and simple to use. The Pneumatic System permits to maintain low temperatures of flours thanks to the high air volume which flows through the grinding chamber. Moreover, this system allows to maintain the work place clean and powderless, as the Mill is kept in depression and the air is filtered before being discharged in the environment. Energy consumptions are contained in 1.12 KW, the system can be supplied with single-phase 230 Volt motor or with three-phase 400 Volt motor. The Pneumatic System is available as a kit and can be coupled to all Combi Junior milling plants that have been manufactured since the year 2013.

Mod.	Net weight Kg	Gross weight Kg	Power supply Volt	Power KW	Max capacity Kg/h
SD 250	45	65	230 - 400	0.75+0,18	75-80

MILLING PLANT WITH CYCLON MOD. SD 250



Mod.	Net Weight Kg	Gross weight Kg	Max length Cm	Max width Cm	Max height Cm	Total power KW	Production fine /coarse Kg/h
Combi Junior + SD 250	190	270	280	80	220	3.1	50/80



FORLI' - Via Ugo Buli, 2 - 47122 Italy - Tel. +39.0543.796165
www.partisani.com - info@partisani.com

Technical data are not binding—we reserve the right to make modifications anytime

